

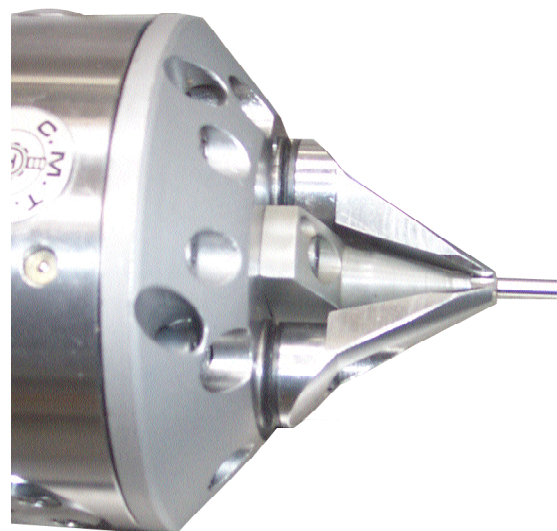

**AUTOMATIC DEVICE  
FOR SMALL SIZE TAPS (M3-M30)  
DRIVING ON A GRINDING MACHINE ON CENTERS**

### MAIN FEATURES

- > driving by means of clamping without influencing the positioning got by centers
- > quick set-up
- > feeding both pneumatic or hydraulic
- > loading both manual or automatic
- > specific sizing to allow passage of grinding wheels for multidirectional machining
- > centrifugal force balancing
- > protections against dirt



### Device in the picture:

- device diam. mm 120 with jaws sizing to allow grinding wheels passage.
- system realized to clamp a tap range from M3 up to M30, suitable also for bigger size taps.
- device is provided with built-in cylinder for automatic movement of the jaws, fed by rear distributor.

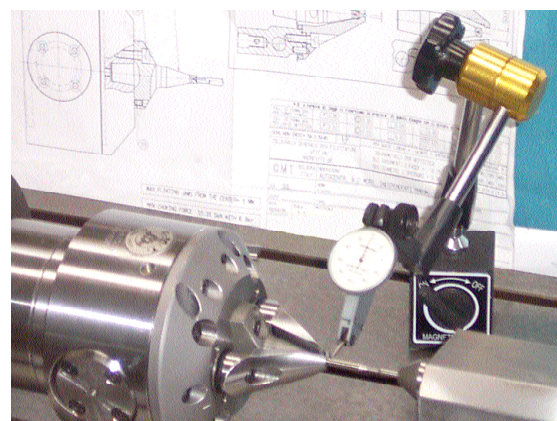

**CMT Tubertini s.r.l.**

40138 BOLOGNA - ITALY - Via del Legatore, 1 - Tel.+39 051.53.02.20 - Fax +39 051.53.59.54  
info@cmt-tubertini.com - www.cmt-tubertini.com